

# SENTIR<sup>®</sup> *mat*

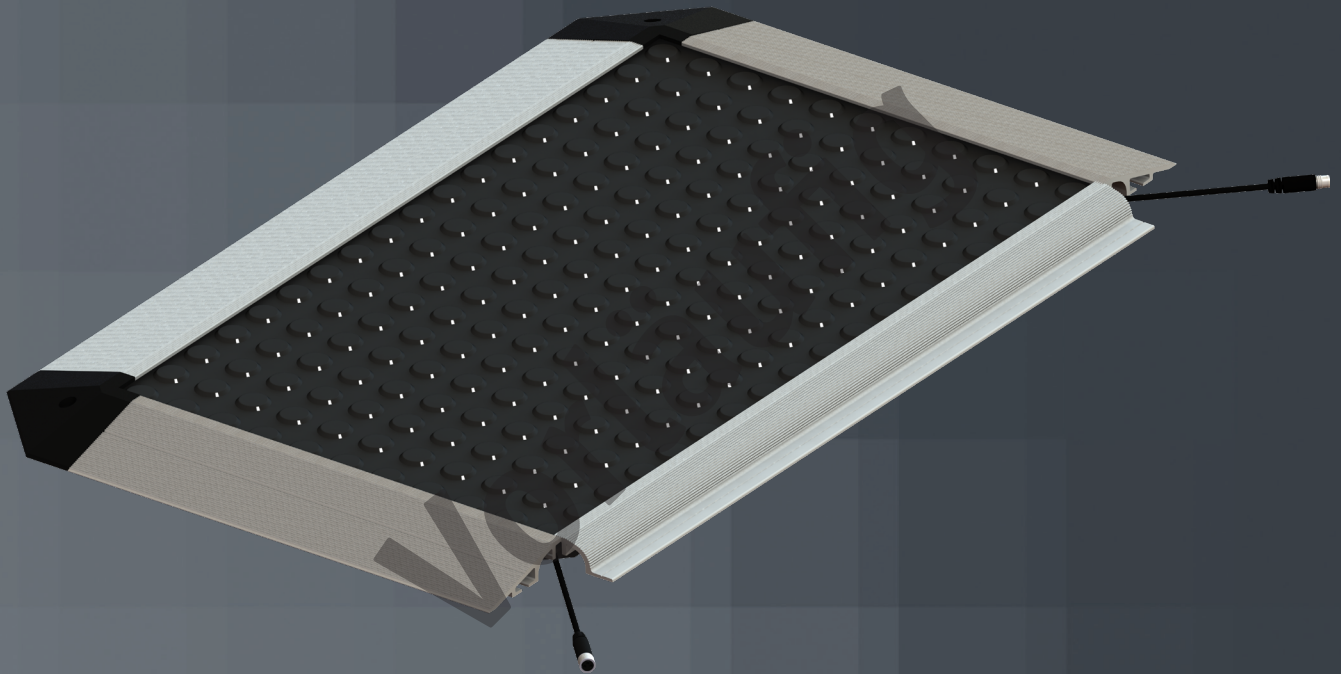

Product Information

## The principle of the safety-contact-mat

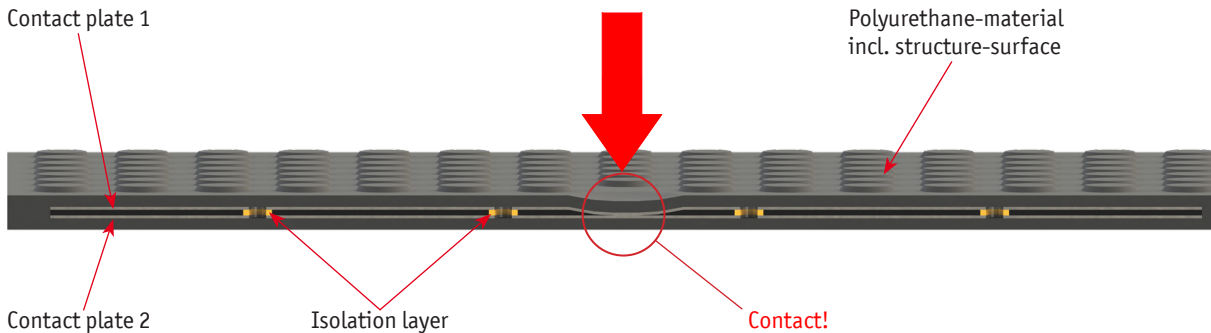

## The structure

The basic construction of the ASO Safety Contact Mat consist of two conductive plates which are separated by a proprietary isolating layer. These plates are completely potted in a polyurethane material so that they are impervious to oil, water and dirt. The top consists of a slip resistant checkered pattern. This surface provides excellent resistance against oil and grease. Two cable exits are provided. These cables consist of one M8 male plug and one M8 female plug in standard construction (optional cable exits are available upon request). Mounting to the floor can be realized with optional aluminum ramp rails RS 14 or BS 14.

## Signal processing

The SENTIR mat safety contact mat is fitted with 2 two-core connecting cables and offers the possibility of connecting several mats in series up to a maximum total area of 10 m<sup>2</sup>. One end of the cable is connected to the safety evaluation control electronics and the terminal resistance is connected to the other end (prepared at the factory). The safety evaluation control electronics provides monitoring for the entire circuit including the cabling route and the mats, by monitoring the terminal resistance. The two surfaces of the mat make contact when stepped on and the resistance is bridged. This immediately causes a signal within the electronics that is then given as a potential free output for the contact-mat by the relay. The entire switching circuit is monitored at the same time for damage to cable or manipulation.

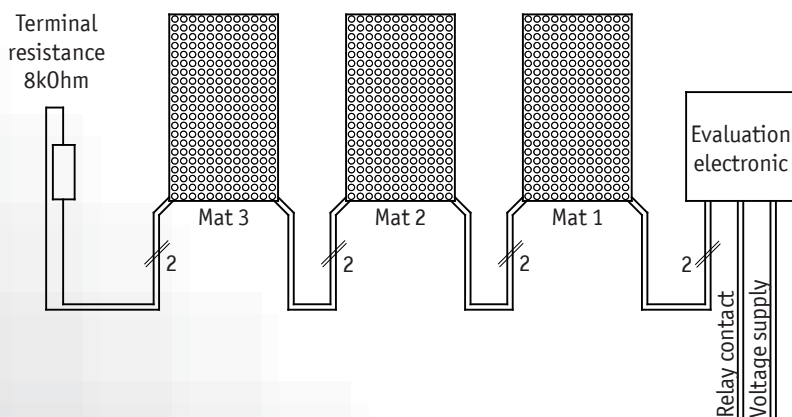

### **Please pay attention to:**

- Up to 10 contact mats wired in series may be connected to one evaluation control unit. The maximum total area can not exceed 10m<sup>2</sup>!
- The total cable length can not exceed 25m.
- The 8.2 kΩ terminal resistance must be connected to the last mat in series when several mats are connected!
- Please inquire separately for mats with recesses or special shapes.

## Ramp rail

The ramp rail RS 14 provides secure mounting capability for the safety contact mat. The angled design reduces tripping and slipping when mounted to the mat. The integrated channel can be used for clean and safe installation of the connecting cable.

## Mounting rail BS 14

The mounting rail BS 14 can be used to attach the safety contact mat in less accessible areas (for example at machines, shut-off positions, walls, etc.). Also the integrated channel can be used for clean and safe installation of the connecting cable.

### SENTIR mat 14

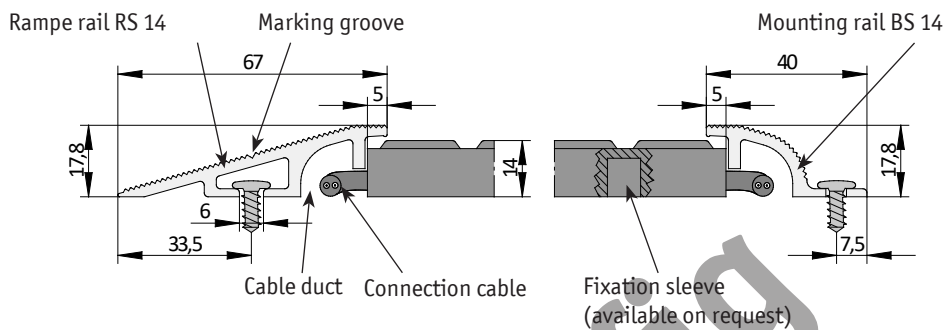

### SENTIR mat 14 ARB (SENTIR mat 14 TBV)

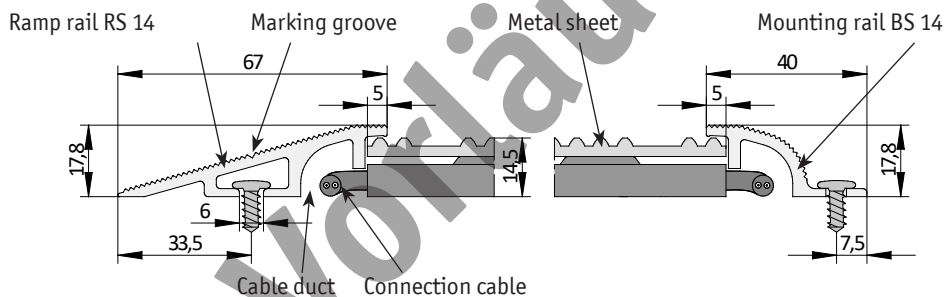

## Fixation sleeve

This enables the safety contact mat to be fixed to the floor without additional space being needed.

## Covers

Special covers or colors on request.

- NP** - Euro dot surface with one compound mat
- SA** - Sandy surface with one compound mat
- ARB** - One compound mat with aluminum plate
- TBV** - One compound mat with stainless steel plate

## Type code information

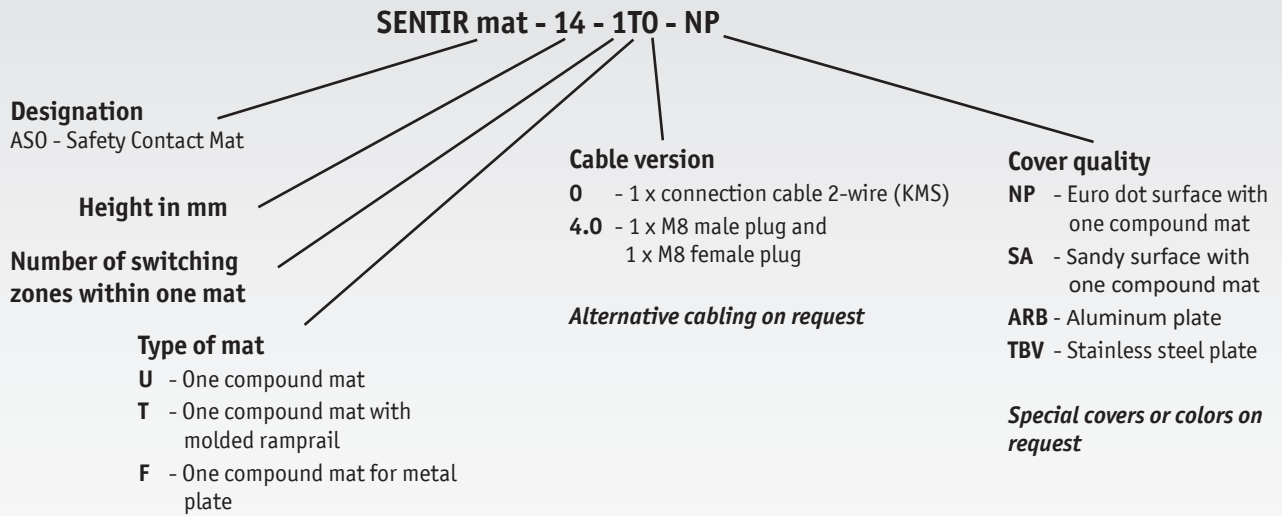

## Technical specification for Safety contact mats

	SENTIR mat 14 U/ SENTIR mat 14 T	SENTIR mat 14 ARB
<b>Max. dimensions</b>	2000 mm x 1250 mm	2000 mm x 1250 mm
<b>Standard dimensions available from stock</b>	only SENTIR mat 14 U / T 1000 mm x 750 mm 1000 mm x 1000 mm 1000 mm x 1500 mm	
<b>Construction height</b>	14 mm with covering	14 mm with covering
<b>Surface</b>	Euro dot	checkered
<b>Weight</b>	U 24,9 Kg/m <sup>2</sup> ; T 26 Kg/m <sup>2</sup>	approx. 31,5 kg/m <sup>2</sup>
<b>Inactive border</b>	16/42 mm	30/40 mm
<b>Switching pressure</b>	Round body Ø 80 mm = approx. 150 N	Round body Ø 80 mm = approx. 150 N
<b>Static load</b>	max. 2000 N over Ø 80 mm *	max. 2000 N over Ø 80 mm *
<b>Response time</b>	< 25 ms *	< 25 ms *
<b>Switching cycles</b>	at least 1 million *	at least 1 million *
<b>*Certificates</b>	EN ISO 13856-1 EN ISO 13849-1 UKCA	EN ISO 13856-1 EN ISO 13849-1 UKCA
<b>Electrical capacity</b>	24 V 100 mA	24 V 100 mA
<b>Material</b>	PUR black, 78 +/- 5 Shore A	PUR black, 78 +/- 5 Shore A
<b>Protection class</b>	IP 65 (IP 67)	IP 65 (IP 67)
<b>Temperature range</b>	-10°C to +55°C	-20°C to +55°C
<b>Chem. resistance:</b> <i>Oil</i> <i>Fuel</i> <i>Solvent</i> <i>Acid diluted</i> <i>Base diluted</i>	good resistant sufficient resistant resistant	<b>Aluminium</b> good good good good good
<b>Maintenance</b>	The mat is maintenance free. Functional testing on an annual basis is recommended.	
<b>Connection cable</b>	Standard: 2 pcs. - 2 x 0,34 PVC / PU cover black Ø 3,5 mm with M8 male/female plug 120 mm (4,72") Alternative: 1 pc. 4 x 0,25 PVC / PU cover black Ø 4,4 mm with open wires (BN: 1, BU: 3     WH: 2, BK: 4)	



## Technical specifications for equipment

### Technical specifications ramp rail RS 14

<b>Application:</b>	SENTIR mat 14
<b>Articel-No.:</b>	603001
<b>Material:</b>	Aluminum AlMgSi 0,5
<b>Standard length of delivery:</b>	3 m
<b>Weight:</b>	approx. 788 g/m

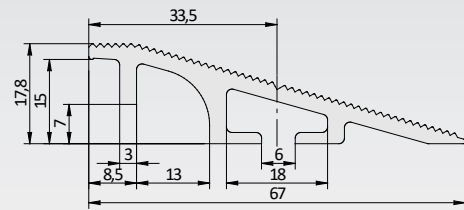

### Technical specifications mounting rail BS 14

<b>Application:</b>	SENTIR mat 14
<b>Articel-No.:</b>	603003
<b>Material:</b>	Aluminium AlMgSi 0,5
<b>Standard length of delivery:</b>	3 m
<b>Weight:</b>	approx. 411 g/m

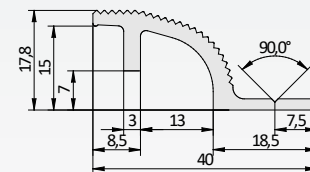

### Technical specifications corner connector EVA

<b>Application:</b>	SENTIR mat 1
<b>Articel-No.:</b>	603020
<b>Material:</b>	PA 6 30% DV, black
<b>Weight:</b>	ca. 29 g/pcs.

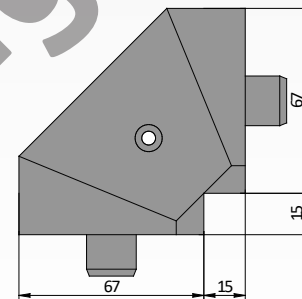

### Technical specifications checkered plate cover

<b>Application:</b>	SENTIR mat 14 ARB
<b>Articel-No.:</b>	1600028
<b>Material:</b>	Aluminum 2,5/4 mm, max. 2500 x 1400 mm
<b>Weight:</b>	approx. 7,6 kg/m <sup>2</sup>

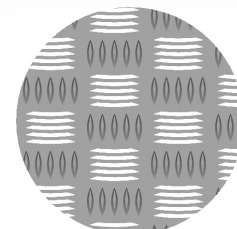

Aluminum checkered plate

### Technical specifications bulb plate cover

<b>Application:</b>	SENTIR mat 14 TBV
<b>Articel-No.:</b>	1600016
<b>Material:</b>	Stainless steel 1,5/2 mm, max. 2500 x 1250 mm
<b>Weight:</b>	approx. 11,6 kg/m <sup>2</sup>

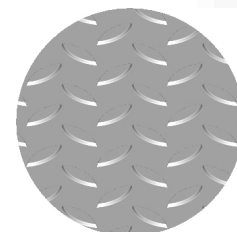

Stainless steel bulb plate



### Assembly Information

The mounting surface must be absolutely even, clean and dry.  
Mats may not be glued on the bottom.

Lay out and position the mat correctly with the base plate downwards. Mats may not be broken or bent. Safety-Contact-Mats may not be changed in any way. Cut outs or shortening is not possible.

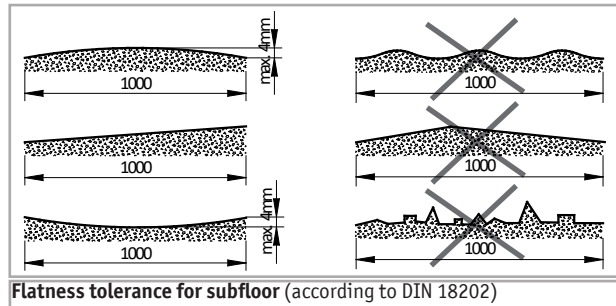

Flatness tolerance for subfloor (according to DIN 18202)

### Please note for measurement:

The ramp rail resp. the mounting rail are used for the fixation of the mat.

To calculate the necessary space needed for the mat, the additional size of the ramp rail(s) resp. mounting rail(s) has to be added to the dimension of the safeguarded area.

	Ramp rail	additional size	mounting rail	additional size
<b>SENTIR mat 14</b>	RS 14 Aluminum	62 mm	BS 14 Aluminum	35 mm
<b>SENTIR mat 14 T</b>	molded	30 mm	- / -	- / -
<b>SENTIR mat 14 ARB</b>	RS 14 Aluminum	62 mm	BS 14 Aluminum	35 mm
<b>SENTIR mat 14 TBV</b>	RS 14 Aluminum	62 mm	BS 14 Aluminum	35 mm

Available space for safeguarding:

**1200 x 500 mm**

Required Safety contact mat:

**SENTIR mat 14** with ramp rail **RS 14** and mounting rail **BS 14**

Example of calculation:

$$1200 \text{ mm} - 62 \text{ mm} - 62 \text{ mm} = 1076 \text{ mm}$$

$$500 \text{ mm} - 62 \text{ mm} - 35 \text{ mm} = 403 \text{ mm}$$

Ordering example:

**SENTIR mat 14 1000 x 400 mm** with **RS 14** and **BS 14**

also with specification for positions of RS 14, BS 14 and cable outlet

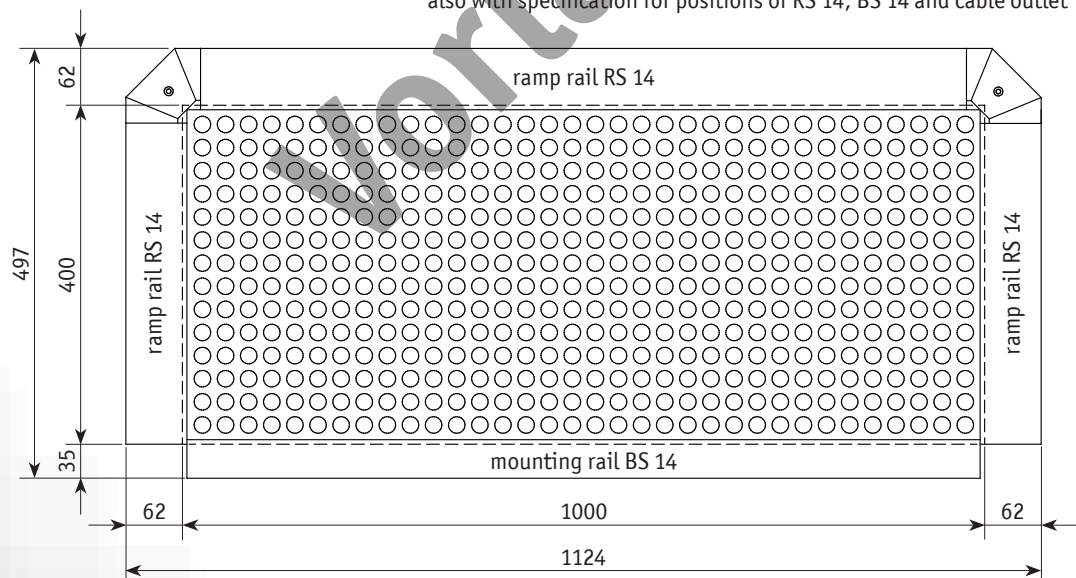

2000 mm x 1250 mm is the maximum producible size of a mat. All dimensions larger than this have to be realized by using several mats.

When installing several mats next to each other they are put together edge to edge.

Then connect the mats electrically and check the resistance value.

With not activated mat the value must be  $8,2 \text{ k}\Omega \pm 500 \Omega$ .

During cable laying inside the ramp- and/or in the mounting rail pay attention that the cable is not pinched.

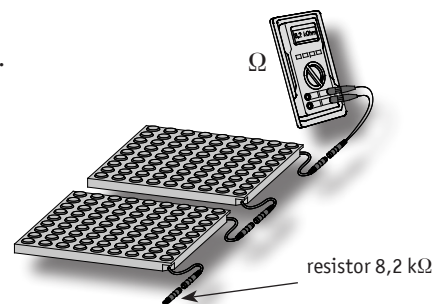

## Assembly of SENTIR mat 14

When using corner connectors the ramp rail must be shortened around 20mm for each corner connector. The corner connector nearest the cable is to be mounted from above over the cable in such a way that the cable is guided safely in the cable duct (fig. 1). Afterwards drill and fasten it to the bottom with 6 mm dowel and suitable screw.

Push the ramp rails laterally to the mat and then on the fixation-pin of the corner connector (fig. 2). Mark the fastening points along the marking groove on the rail and pre-drill 10 mm for the intended plugs. Fasten the rails on the bottom with 6 mm dowels and suitable screws (approx. all 60 cm) and close the openings with the plugs (fig. 3).

Push the corner connectors laterally to the mat and then the fixation-pin into the rail (fig. 4). Afterwards drill and fasten it to the bottom with 6 mm dowel and suitable screw.

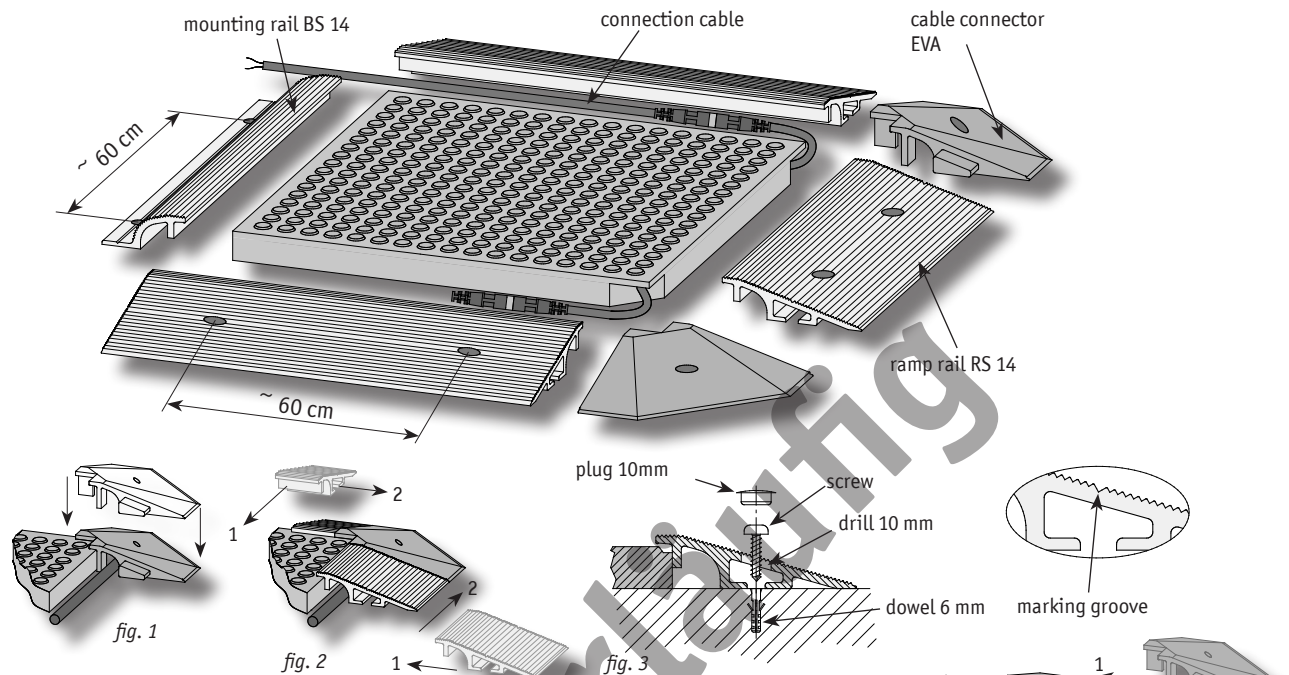

At the machine side the conclusion takes place via the adjustment with the mounting rail BS 14. Fasten the rail to the bottom with 6 mm dowels and suitable screws (approx. all 60 cm). If possible bring out the cable laterally and attach it to the controller (fig. 5).

## SENTIR mat 14 ARB / SENTIR mat 14 TBV

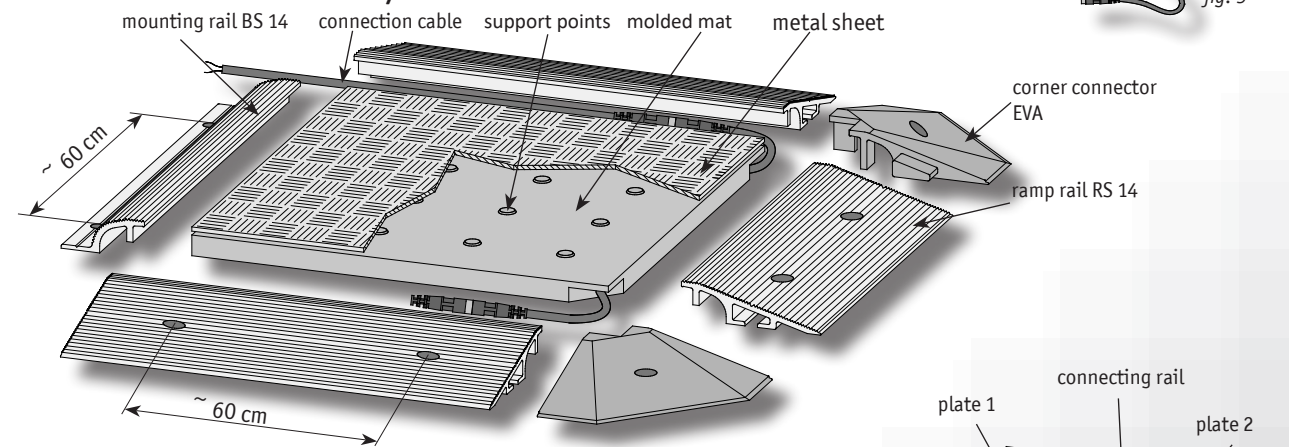

Mounting mats with metallic plates of aluminum (ARB) or stainless steel (TBV), make sure that the plates are only placed and fixed by the surrounding rails.

**The plates must not be stuck!**

Multiple metal plates must be connected by connecting rails (fig. 6).

# Assembly of mats with molded ramp rails SENTIR mat 14 T

## Please note for dimensioning:

The area to be safeguarded is the dimensions of the mat without the ramp rails. Therefore 30mm have to be added for each ramp rail side. The result is the over-all dimension for the floor space.

The ramp rail serves for fixation to the ground.

2000mm x 1250mm is the maximum producible size of a mat (area for safeguard). All dimensions larger than this have to be realized by using several mats.

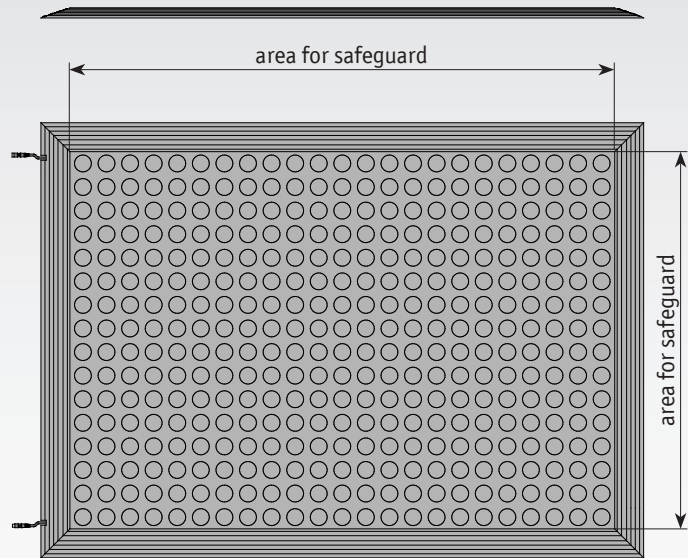

## Installation

Cut out the cable output at appropriate side in that way that the coming out cables are not squeezed or sheared while placing the mat afterwards. Place and adjust the mat at appropriate place. To provide against slipping use suitable screws and dowels on each side of the mat.

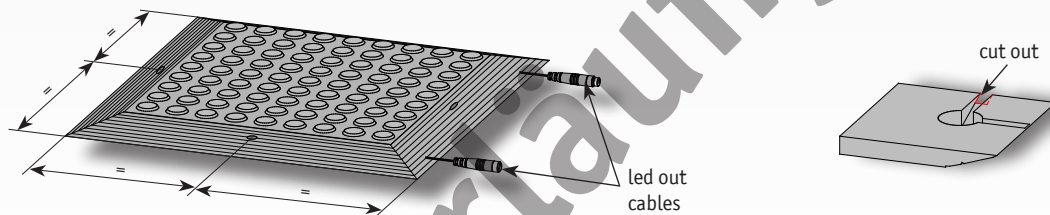

When installing several mats next to each other they are put together edge to edge. To do this cut off the ramp rail with a knife in the given slit (spray the knife and the cutting area with soapy water (fig. 10)).

Adjust the mats and save each against getting out of place (fig. 11).

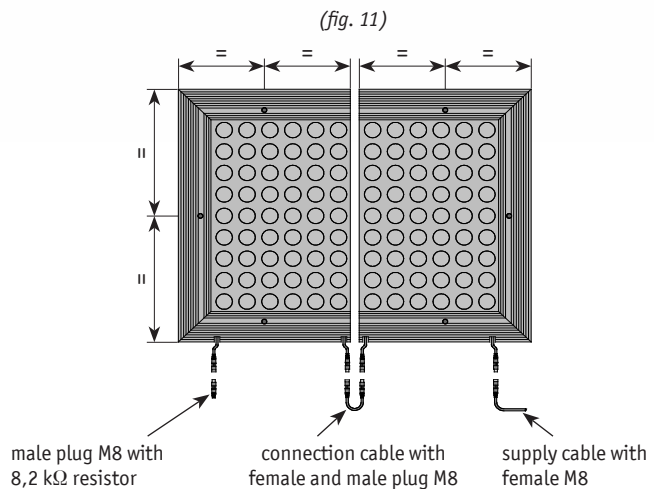
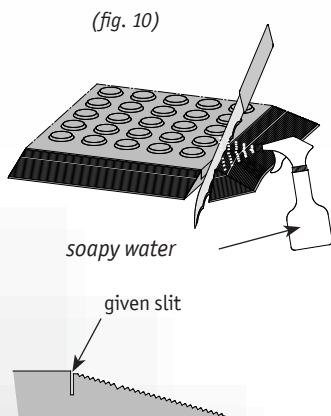

**For traffic safety the cable outputs should allways be aligned to the machine side!**

Unevenness and/or small inclusions of air which can appear on the back of the mat, do not affect the functionality of the SENTIR mat in a negative way. These kind of visual appereances are caused during the production process and can not be complained.

## Functional testing

After that connect the mats electrically and check the resistance value. With not activated mat the value must be  $8,2 \text{ k}\Omega \pm 500 \Omega$ . When the mat is actuated, the resistance value must be  $<50 \Omega$ .



### Storage

- SENTIR mats have to be stored dry ( $-20^{\circ}\text{C} / +70^{\circ}\text{C}$ )
- SENTIR mats have to be stored horizontally on a continuous even surface
- Do not stack more than 20 SENTIR mats on top of each other

1. No safety functions have been evaluated by UL

2. When the device is not supplied by Class 2 source, the input shall be protected by a fuse with a current rating of 100 divided by the supply voltage, not to exceed 5 Amps

Vorläufig

# EC - Declaration of conformity

**EG - Konformitätserklärung** (gemäß Anhang II 2006/42/EG)  
**EC Declaration of conformity** (according annex II 2006/42/EC)  
**Déclaration de conformité CE** (selon annexe II 2006/42/CE)



Hiermit erklären wir, dass die nachfolgend bezeichneten Schaltleisten

We hereby declare that the following products of sensing contact edges

Par la présente nous déclarons que les produits suivants de la série barres palpeuses:

**SENTIR mat 10 / 10T**  
**SENTIR mat 14 / 14T**

**SENTIR mat 10 / 10T**  
**SENTIR mat 10 / 14T**

**SENTIR mat 10 / 10T**  
**SENTIR mat 10 / 14T**

zur Kombination mit den Sicherheitsschaltgeräten der Baureihe

for the combination with safety relays of the model range

en combinaison avec les relais de sécurité

**ELMON classic 31**  
**ELMON classic/rail 32**  
**ELMON rail 34**  
**ELMON rail 35**  
**ELMON rail 39**  
**ELMON classic/rail 41**

**ELMON classic 31**  
**ELMON classic/rail 32**  
**ELMON rail 34**  
**ELMON rail 35**  
**ELMON rail 39**  
**ELMON classic/rail 41**

**ELMON classic 31**  
**ELMON classic/rail 32**  
**ELMON rail 34**  
**ELMON rail 35**  
**ELMON rail 39**  
**ELMON classic/rail 41**

aufgrund ihrer Konzipierung und Bauart sowie in der von uns in Verkehr gebrachten Ausführung, den einschlägigen grundlegenden Sicherheits- und Gesundheitsanforderungen der nachfolgenden EG-Richtlinien und Normen entspricht:

satisfies the relevant essential health and safety requirements of the EC directives and standards listed below on account of its design and construction, as does the version brought to market by us:

de par sa conception et sa construction, ainsi que dans les modèles mis en circulation par nos soins, répondent aux exigences de base pour la sécurité et la santé des directives et normes CE suivantes :

**2006/42/EG**  
**EN ISO 13856-1:2013**  
**EN ISO 13849-1:2008**

**2006/42/EC**  
**EN ISO 13856-1:2013**  
**EN ISO 13849-1:2008**

**2006/42/CE**  
**EN ISO 13856-1:2013**  
**EN ISO 13849-1:2008**

EG-Baumusterprüfung  
 Notified Body 0044  
 TÜV Nord Cert GmbH  
 Langemarckstraße 20  
 D-45141 Essen  
 Nr. 44 205 11 384662 002

EC type-examination  
 Notified Body 0044  
 TÜV Nord Cert GmbH  
 Langemarckstraße 20  
 D-45141 Essen  
 No. 44 205 11 384662 002

Examen CE de type  
 Notified Body 0044  
 TÜV Nord Cert GmbH  
 Langemarckstraße 20  
 D-45141 Essen  
 N° 44 44 205 11 384662 002

Diese Konformitätserklärung entbindet den Konstrukteur/ Hersteller der Maschine nicht von seiner Pflicht, die Konformität der gesamten Maschine, an der dieses Produkt angebracht wird, entsprechend der EG-Maschinenrichtlinie sicherzustellen.

This declaration of conformity does not relieve the designer / manufacturer of the machine from his obligation to ensure that the conformity of the entire machine to which this product is attached satisfies the corresponding EC directive.

Cette déclaration de conformité ne délie pas le constructeur / fabricant de la machine de son obligation d'assurer la conformité de l'ensemble de la machine à laquelle ce produit est apposé selon la directive CE.

**Hersteller und Dokumentationsbevollmächtigter**

**Manufacturer and attorney of documents**

**Fabricant et agent de documentation**

**ASO GmbH**  
 Hansastr. 52  
 D-59557 Lippstadt  
 Lippstadt, 08.05.2014

  
 H. Friedrich  
 - Geschäftsführer - CEO - Gérant -



# EC - Declaration of conformity

**EG - Konformitätserklärung** (gemäß Anhang II 2006/42/EG)  
**EC Declaration of conformity** (according annex II 2006/42/EC)  
**Déclaration de conformité CE** (selon annexe II 2006/42/CE)



Hiermit erklären wir, dass die nachfolgend bezeichneten Schaltleisten

We hereby declare that the following products of sensing contact edges

Par la présente nous déclarons que les produits suivants de la série barres palpeuses:

**SENTIR mat 14 ARB**  
**SENTIR mat 14 TBV**

**SENTIR mat 14 ARB**  
**SENTIR mat 14 TBV**

**SENTIR mat 14 ARB**  
**SENTIR mat 14 TBV**

zur Kombination mit den Sicherheitsschaltgeräten der Baureihe

for the combination with safety relays of the model range

en combinaison avec les relais de sécurité

**ELMON classic 31**  
**ELMON classic/rail 32**  
**ELMON rail 34**  
**ELMON rail 35**  
**ELMON rail 39**  
**ELMON classic/rail 41**

**ELMON classic 31**  
**ELMON classic/rail 32**  
**ELMON rail 34**  
**ELMON rail 35**  
**ELMON rail 39**  
**ELMON classic/rail 41**

**ELMON classic 31**  
**ELMON classic/rail 32**  
**ELMON rail 34**  
**ELMON rail 35**  
**ELMON rail 39**  
**ELMON classic/rail 41**

aufgrund ihrer Konzipierung und Bauart sowie in der von uns in Verkehr gebrachten Ausführung, den einschlägigen grundlegenden Sicherheits- und Gesundheitsanforderungen der nachfolgenden EG-Richtlinien und Normen entspricht:

satisfies the relevant essential health and safety requirements of the EC directives and standards listed below on account of its design and construction, as does the version brought to market by us:

de par sa conception et sa construction, ainsi que dans les modèles mis en circulation par nos soins, répondent aux exigences de base pour la sécurité et la santé des directives et normes CE suivantes :

**2006/42/EG**  
**EN ISO 13856-1:2013**  
**EN ISO 13849-1:2008**

**2006/42/EC**  
**EN ISO 13856-1:2013**  
**EN ISO 13849-1:2008**

**2006/42/CE**  
**EN ISO 13856-1:2013**  
**EN ISO 13849-1:2008**

EG-Baumusterprüfung  
 Notified Body 0044  
 TÜV Nord Cert GmbH  
 Langemarckstraße 20  
 D-45141 Essen  
 Nr. 44 205 11 384662 001

EC type-examination  
 Notified Body 0044  
 TÜV Nord Cert GmbH  
 Langemarckstraße 20  
 D-45141 Essen  
 No. 44 205 11 384662 001

Examen CE de type  
 Notified Body 0044  
 TÜV Nord Cert GmbH  
 Langemarckstraße 20  
 D-45141 Essen  
 N° 44 44 205 11 384662 001

Diese Konformitätserklärung entbindet den Konstrukteur/ Hersteller der Maschine nicht von seiner Pflicht, die Konformität der gesamten Maschine, an der dieses Produkt angebracht wird, entsprechend der EG-Maschinenrichtlinie sicherzustellen.

This declaration of conformity does not relieve the designer / manufacturer of the machine from his obligation to ensure that the conformity of the entire machine to which this product is attached satisfies the corresponding EC directive.

Cette déclaration de conformité ne délie pas le constructeur / fabricant de la machine de son obligation d'assurer la conformité de l'ensemble de la machine à laquelle ce produit est apposé selon la directive CE.

**Hersteller und Dokumentationsbevollmächtigter**

**Manufacturer and attorney of documents**

**Fabricant et agent de documentation**

**ASO GmbH**  
 Hansastr. 52  
 D-59557 Lippstadt  
 Lippstadt, 13.03.2015



Helmut Friedrich  
 - Geschäftsführer - CEO - Gérant -



# UKCA Declaration of conformity

**UKCA Declaration of conformity**  
In accordance with UK Government Guidance



We hereby declare that the following products of sensing contact mat

**SENTIR mat 10 / 10T**  
**SENTIR mat 14 / 14T**

satisfies the relevant UK Statutory Instruments and their amendments listed below on account of its design and construction, as does the version brought to market by us:

**2012 No 3032**  
**The Restriction of the Use of Hazardous Substances in Electrical and Electronic Equipment Regulations 2012**

**2008 No 1597**  
**The supply of Machinery (Safety) Regulations 2008**

Also, we declare that the product described above, to which this declaration of conformity refers to, is in conformity with the essential requirements of the following standards:

<b>BS EN 12978+A1</b>	<b>Industrial, commercial and garage doors and gates. Safety devices for power operated doors and gates. Requirements and test methods</b>
<b>BS EN ISO 13849-1</b>	<b>Safety of machinery. Safety related parts of control systems General principles for design</b>
<b>BS EN ISO 13856-1</b>	<b>Safety of machinery. Pressure sensitive protective devices General principles for the design and testing of pressure-sensitive mats and pressure-sensitive floors</b>

This declaration of conformity is issued under the sole responsibility of the product manufacturer.

**Manufacturer and attorney of documents:**

**ASO GmbH**  
Hansastr. 52  
D-59557 Lippstadt  
Lippstadt, 11.04.2023

H. Friedrich  
- Geschäftsführer - CEO - Gérant -



# UKCA Declaration of conformity

## UKCA Declaration of conformity In accordance with UK Government Guidance



We hereby declare that the following products of sensing contact mats

**SENTIR mat 14 ARB**  
**SENTIR mat 14 TBV**

satisfies the relevant UK Statutory Instruments and their amendments listed below on account of its design and construction, as does the version brought to market by us:

**2012 No 3032**

**The Restriction of the Use of Hazardous Substances in Electrical and Electronic Equipment Regulations 2012**

**2008 No 1597**

**The supply of Machinery (Safety) Regulations 2008**

Also, we declare that the product described above, to which this declaration of conformity refers to, is in conformity with the essential requirements of the following standards:

**BS EN ISO 13856-1**

**Safety of machinery. Pressure sensitive protective devices General principles for the design and testing of pressure-sensitive mats and pressure-sensitive floors**

**BS EN ISO 13849-1**

**Safety of machinery. Safety related parts of control systems General principles for design**

This declaration of conformity is issued under the sole responsibility of the product manufacturer.

**Manufacturer and attorney of documents:**

**ASO GmbH**  
Hansastr. 52  
D-59557 Lippstadt  
Lippstadt, 11.04.2023

H. Friedrich  
- Geschäftsführer - CEO - Gérant -

**UK  
CA**

# Notizen

## Notes

Vorläufig

Vorläufig

#### Headquarter Europe

ASO GmbH  
Hansastraße 52  
59557 Lippstadt

**Tel** +49 2941 9793-0  
**Fax** +49 2941 9793-299  
[www.asosafety.de](http://www.asosafety.de)  
[sales-eu@asosafety.com](mailto:sales-eu@asosafety.com)

#### Headquarters USA

ASO Safety Solutions Inc.  
350N Frontage Road  
Landing, NJ 07850

**Phone** +1 973 5869600  
**Fax** +1 973 5861590  
[www.asosafetyus.com](http://www.asosafetyus.com)  
[sales-us@asosafety.com](mailto:sales-us@asosafety.com)

#### Headquarter Asia Pacific

ASO Safety Solutions Nanjing Co. Ltd.  
Jinma Lu 3 Maqun Scientific Park  
210049 Nanjing

**Phone** +86 25 856 73990  
[www.asosafety.cn](http://www.asosafety.cn)  
[sales-cn@asosafety.com](mailto:sales-cn@asosafety.com)



DOC0000177 Technical data Rev 19  
as of 20.05.2026  
Technical changes reserved.