

SENTIR[®] *edge*

25.45

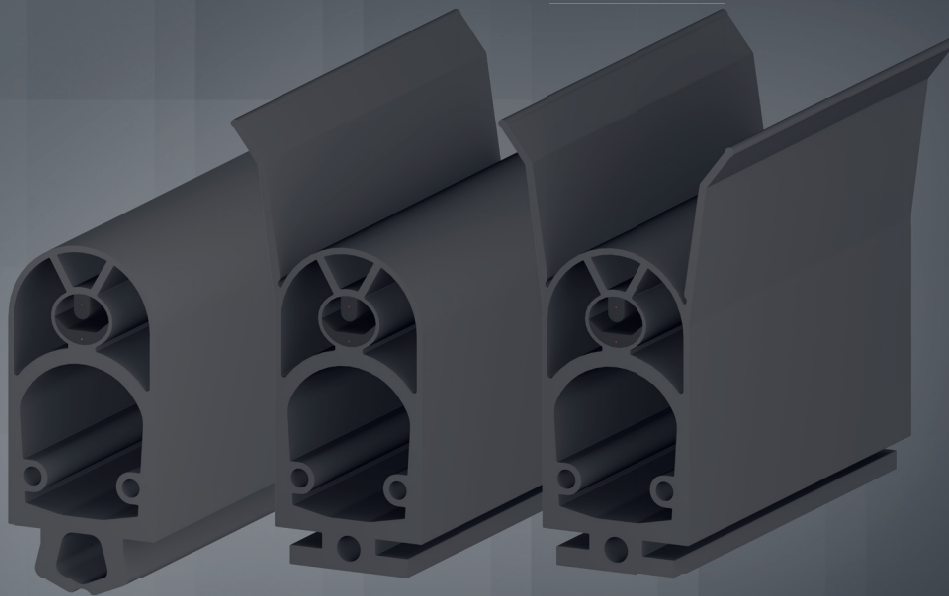

ASO **Safety**
Solutions

Product Information



© ASO Inc.
All Rights Reserved

Specifications

SENTIR *edge*
25.45 CT

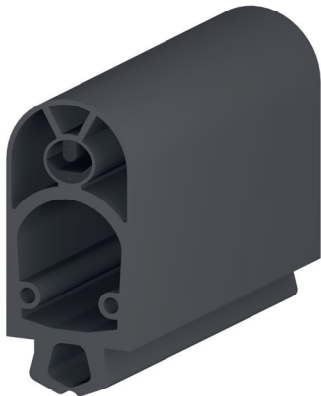

SENTIR *edge*
25.45 TTLa

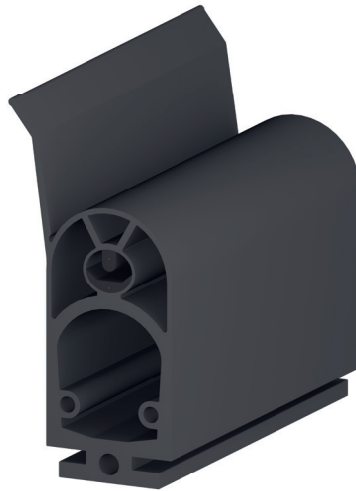

SENTIR *edge*
25.45 TTLL

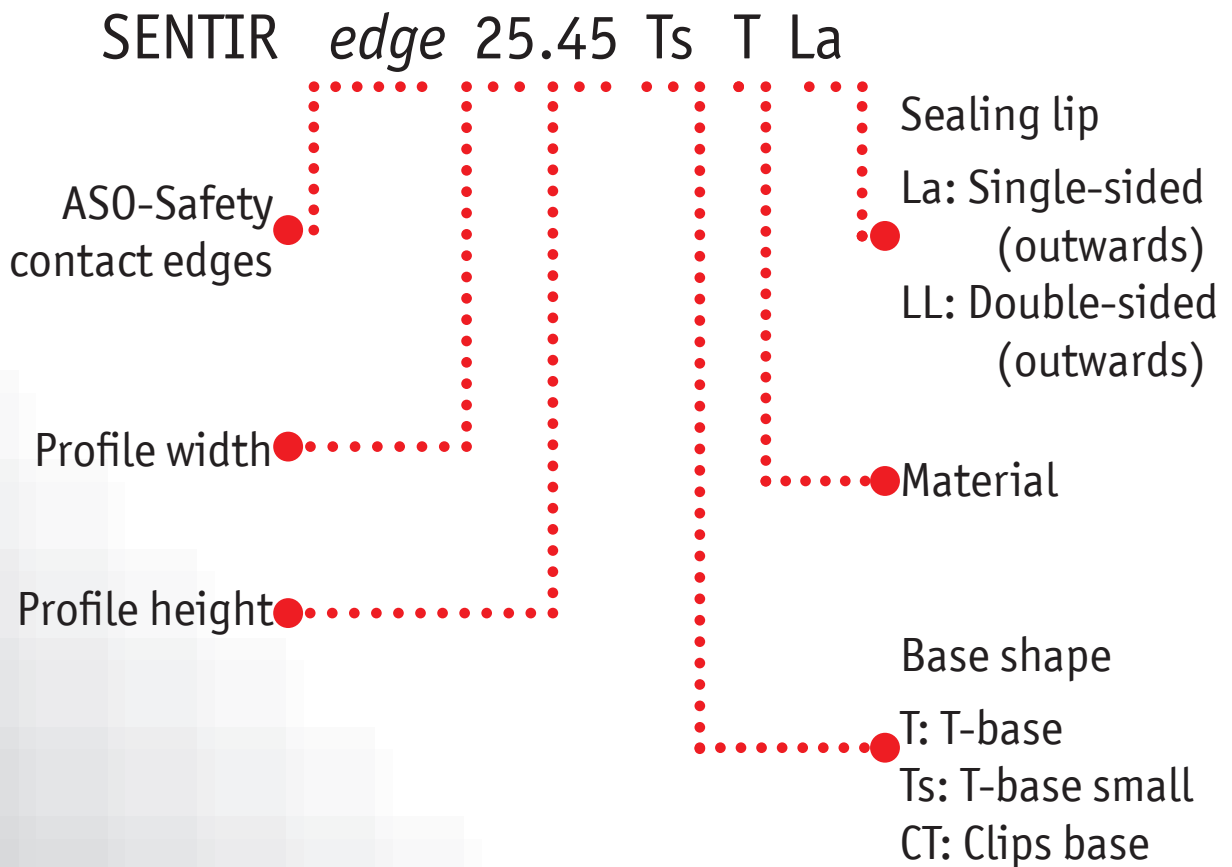
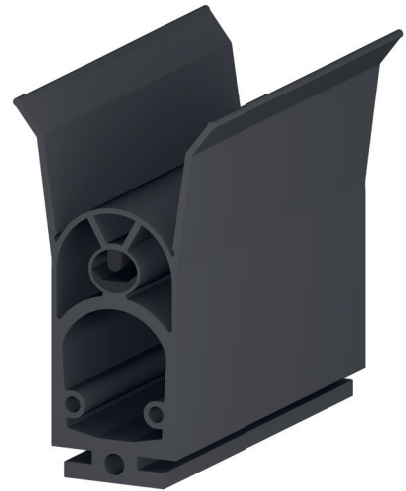

Specifications

SENTIR edge
25.45 CT

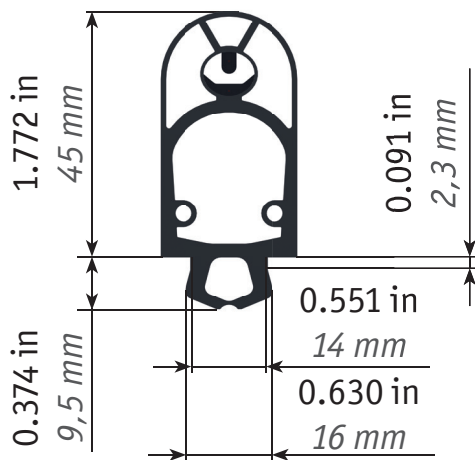

SENTIR edge
25.45 T(s*)TLa

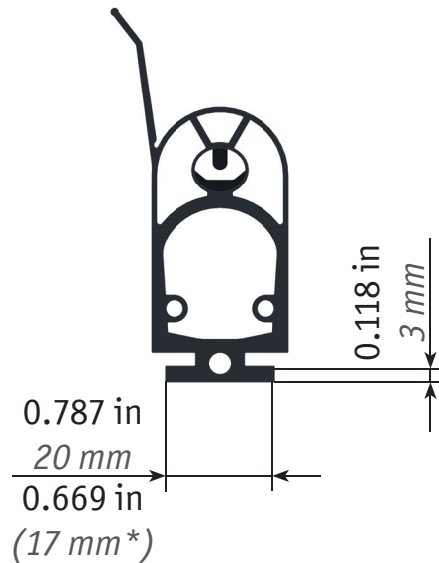

SENTIR edge
25.45 FTLa

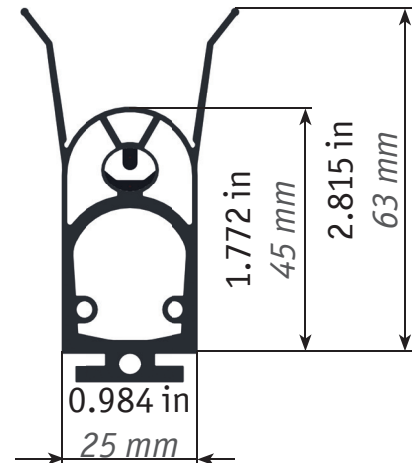

* All shown variants are also available with smaller base shape „Ts“.

Max. Lieferlänge Max. delivery length	98.425 ft / 30 m
Dimensionen Dimensions	0.984 in / 25 mm W x 1.772 in / 45 mm H
Zertifizierungen Certificates	EN ISO 13856-2 EN 12978 EN ISO 13849-1 UL 325

Dimension in inch, *Dimension in mm*, Tolerances according to DIN ISO 3302-1 class E2

Technical data

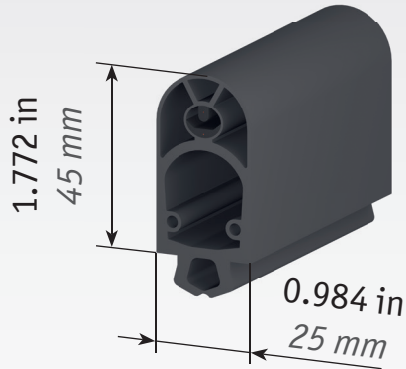

General data	
Type	SENTIR edge 25.45 CT
Article No.	1502-4880
Material	TPE
Material hardness	68 Shore A
Delivery length	98.425 ft / 30m
Weight kg/m	0,61
Enclosure	IP 65 (IP 68 on request)
Switching Cycles	> 30.000 (UL 325)
Switching Angle	2 x 45°
Actuation resistance	≤ 500 Ohm
Electrical capacity	24 V 10 mA
Operating temperature	-10 °C → 50 °C
Max. temperature range	-25 °C → 75 °C
Max. length of several contact edges	328.084 ft / 100 m
Max. series connection of the contact edges	5 Contact edges
Inactive end region with higher forces	1.181in / 30 mm
Connection cables	LIY11Y 2x0,34 mm
Cable material	PUR matt black

Characteristics for test temperature +20 °C

Test-Speed 10 mm/s (0.394 in/s)

Actuation Force F^A	63,1 N
Actuation distance c	0.283 in (7,2 mm)
Overtravel distance d to 250 N	0.764 in (19,4 mm)
Overtravel distance f to 400 N	0.929 in (23,6 mm)
Overtravel distance h-c to 600 N	1.039 in (26,4 mm)

Tested according DIN EN ISO 13856-2, Test Unit round 80mm, Actuating Point C3, Temp. 20°C

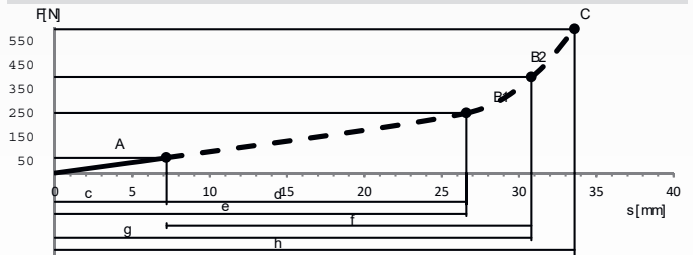

Test-Speed 100 mm/s (3.937 in/s)

Actuation Force F^A	53,9 N
Actuation distance c	0.303 in (7,7 mm)
Overtravel distance d to 250 N	0.783 in (19,9 mm)
Overtravel distance f to 400 N	0.894 in (22,7 mm)
Overtravel distance h-c to 600 N	0.976 in (24,8 mm)

Tested according DIN EN ISO 13856-2, Test Unit round 80mm, Actuating Point C3, Temp. 20°C

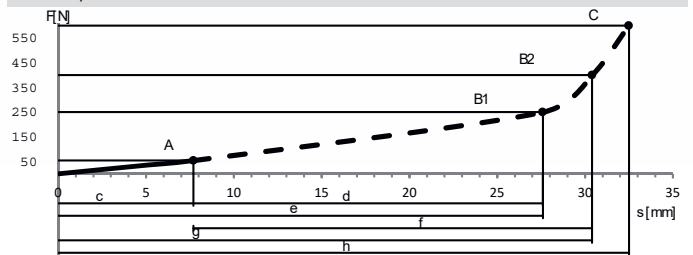

Test-Speed 200 mm/s (7.874 in/s)

Actuation Force F^A	60,4 N
Actuation distance c	0.394 in (10,0 mm)
Overtravel distance d to 250 N	0.780 in (19,8 mm)
Overtravel distance f to 400 N	0.890 in (22,6 mm)
Overtravel distance h-c to 600 N	0.965 in (24,5 mm)

Tested according DIN EN ISO 13856-2, Test Unit round 80mm, Actuating Point C3, Temp. 20°C

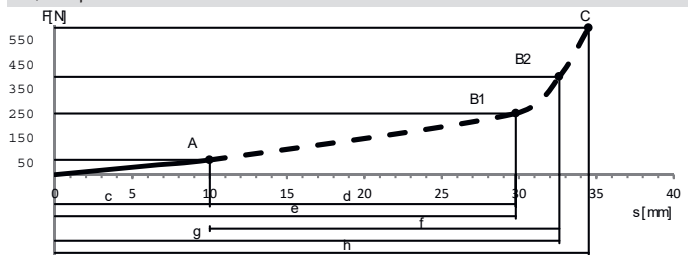

The response time of the used controller affects the measured overtravel distances of the contact edge.

Technical data

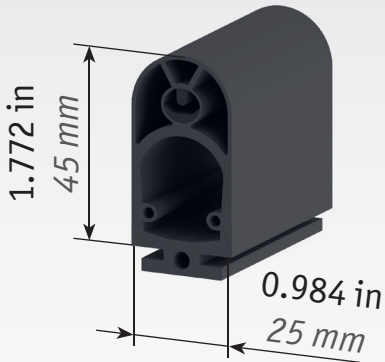

General data	
Type	SENTIR edge 25.45 TT (25.45 TsT)
Article No.	1502-0440 (1502-0910)
Material	TPE
Material hardness	68 Shore A
Delivery length	98.425 ft / 30m
Weight kg/m	0,44
Enclosure	IP 65 (IP 68 on request)
Switching Cycles	> 30.000 (UL 325)
Switching Angle	2 x 45°
Actuation resistance	≤ 500 Ohm
Electrical capacity	24 V 10 mA
Operating temperature	-10 °C → 50 °C
Max. temperature range	-25 °C → 75 °C
Max. length of several contact edges	328.084 ft / 100 m
Max. series connection of the contact edges	5 Contact edges
Inactive end region with higher forces	1.181in / 30 mm
Connection cables	LIY11Y 2x0,34 mm
Cable material	PUR matt black

Characteristics for test temperature +20 °C

Test-Speed 10 mm/s (0.394 in/s)

Actuation Force F^A	63,1 N
Actuation distance c	0.283 in (7,2 mm)
Overtravel distance d to 250 N	0.764 in (19,4 mm)
Overtravel distance f to 400 N	0.929 in (23,6 mm)
Overtravel distance h-c to 600 N	1.039 in (26,4 mm)

Tested according DIN EN ISO 13856-2, Test Unit round 80mm, Actuating Point C3, Temp. 20°C

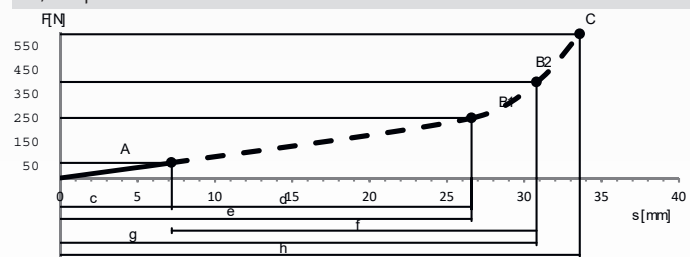

Test-Speed 100 mm/s (3.937 in/s)

Actuation Force F^A	53,9 N
Actuation distance c	0.303 in (7,7 mm)
Overtravel distance d to 250 N	0.783 in (19,9 mm)
Overtravel distance f to 400 N	0.894 in (22,7 mm)
Overtravel distance h-c to 600 N	0.976 in (24,8 mm)

Tested according DIN EN ISO 13856-2, Test Unit round 80mm, Actuating Point C3, Temp. 20°C

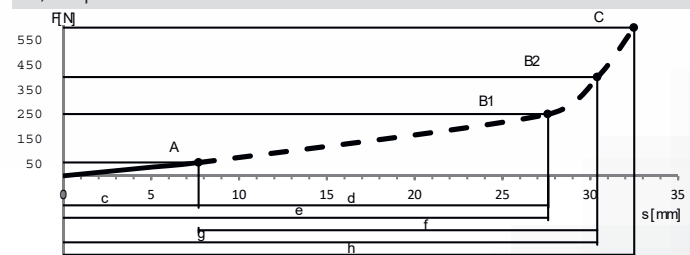

Test-Speed 200 mm/s (7.874 in/s)

Actuation Force F^A	60,4 N
Actuation distance c	0.394 in (10,0 mm)
Overtravel distance d to 250 N	0.780 in (19,8 mm)
Overtravel distance f to 400 N	0.890 in (22,6 mm)
Overtravel distance h-c to 600 N	0.965 in (24,5 mm)

Tested according DIN EN ISO 13856-2, Test Unit round 80mm, Actuating Point C3, Temp. 20°C

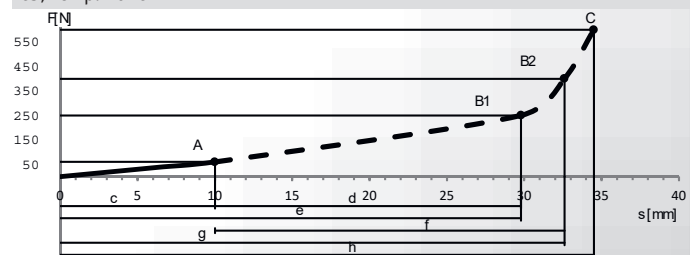

The response time of the used controller affects the measured overtravel distances of the contact edge.

Technical data

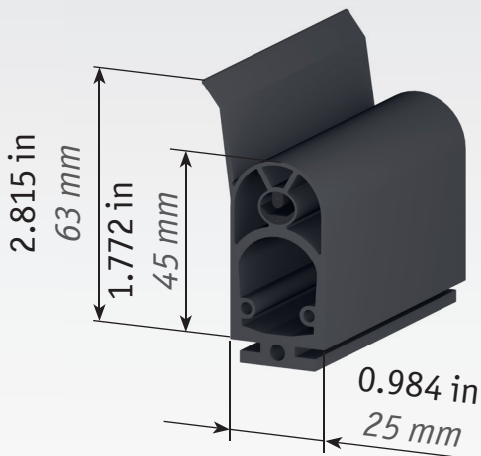

General data	
Type	SENTIR edge 25.45 TTLa (25.45 TsTLa)
Article No.	1502-0560 (1502-0950)
Material	TPE
Material hardness	68 Shore A
Delivery length	98.425 ft / 30m
Weight kg/m	0,47
Enclosure	IP 65 (IP 68 on request)
Switching Cycles	> 30.000 (UL 325)
Switching Angle	2 x 45°
Actuation resistance	≤ 500 Ohm
Electrical capacity	24 V 10 mA
Operating temperature	-10 °C → 50 °C
Max. temperature range	-25 °C → 75 °C
Max. length of several contact edges	328.084 ft / 100 m
Max. series connection of the contact edges	5 Contact edges
Inactive end region with higher forces	1.181in / 30 mm
Connection cables	LIY11Y 2x0,34 mm
Cable material	PUR matt black

Characteristics for test temperature +20 °C

Test-Speed 10 mm/s (0.394 in/s)

Actuation Force F ^A	71,9 N
Actuation distance c	0.402 in (10,2 mm)
Overtravel distance d to 250 N	0.909 in (23,1 mm)
Overtravel distance f to 400 N	1.091 in (27,7 mm)
Overtravel distance h-c to 600 N	1.213 in (30,8 mm)

Tested according DIN EN ISO 13856-2, Test Unit round 80mm, Actuating Point C3, Temp. 20°C

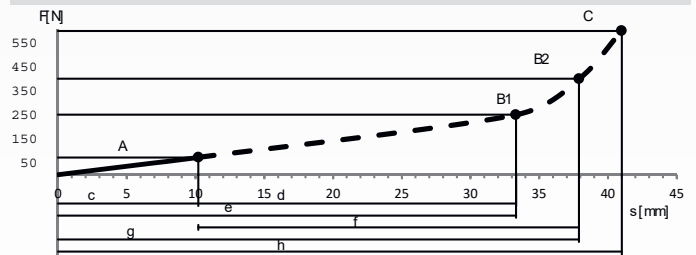

Test-Speed 100 mm/s (3.937 in/s)

Actuation Force F ^A	59,3 N
Actuation distance c	0.425 in (10,8 mm)
Overtravel distance d to 250 N	0.898 in (22,8 mm)
Overtravel distance f to 400 N	1.031 in (26,2 mm)
Overtravel distance h-c to 600 N	1.130 in (28,7 mm)

Tested according DIN EN ISO 13856-2, Test Unit round 80mm, Actuating Point C3, Temp. 20°C

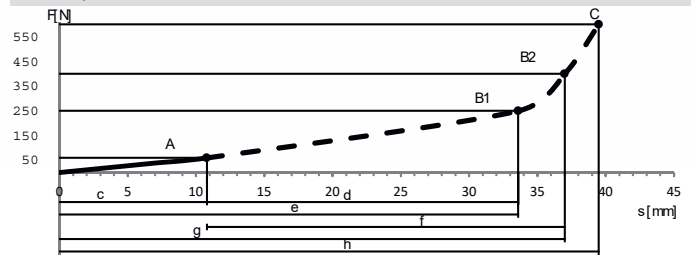

Test-Speed 200 mm/s (7.874 in/s)

Actuation Force F ^A	60,6 N
Actuation distance c	0.445 in (11,3 mm)
Overtravel distance d to 250 N	0.878 in (22,3 mm)
Overtravel distance f to 400 N	1.024 in (26,0 mm)
Overtravel distance h-c to 600 N	1.126 in (28,6 mm)

Tested according DIN EN ISO 13856-2, Test Unit round 80mm, Actuating Point C3, Temp. 20°C

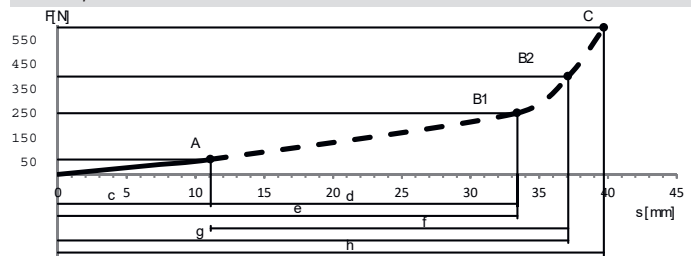

The response time of the used controller affects the measured overtravel distances of the contact edge.

Technical data

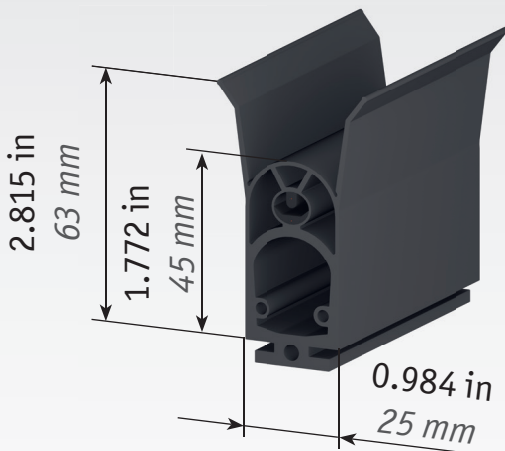

General data	
Type	SENTIR edge 25.45 TLL (25.45 TsLL)
Article No.	1502-0550 (1502-0920)
Material	TPE
Material hardness	68 Shore A
Delivery length	98.425 ft / 30m
Weight kg/m	0,50
Enclosure	IP 65 (IP 68 on request)
Switching Cycles	> 30.000 (UL 325)
Switching Angle	2 x 45°
Actuation resistance	≤ 500 Ohm
Electrical capacity	24 V 10 mA
Operating temperature	-10 °C → 50 °C
Max. temperature range	-25 °C → 75 °C
Max. length of several contact edges	328.084 ft / 100 m
Max. series connection of the contact edges	5 Contact edges
Inactive end region with higher forces	1.181in / 30 mm
Finger safety	0 °C → 50 °C
Connection cables	LIY11Y 2x0,34 mm
Cable material	PUR matt black

Characteristics for test temperature +20 °C

Test-Speed 10 mm/s (0.394 in/s)

Actuation Force F^A	71,9 N
Actuation distance c	0.402 in (10,2 mm)
Overtravel distance d to 250 N	0.909 in (23,1 mm)
Overtravel distance f to 400 N	1.091 in (27,7 mm)
Overtravel distance h-c to 600 N	1.213 in (30,8 mm)

Tested according DIN EN ISO 13856-2, Test Unit round 80mm, Actuating Point C3, Temp. 20°C

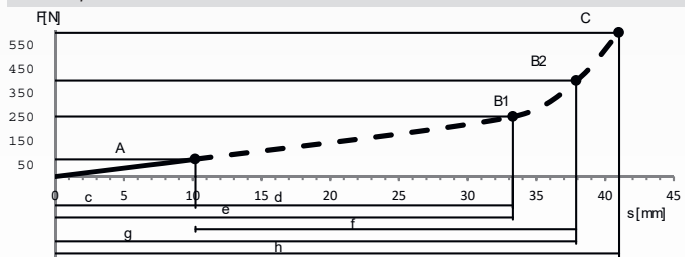

Test-Speed 100 mm/s (3.937 in/s)

Actuation Force F^A	59,3 N
Actuation distance c	0.425 in (10,8 mm)
Overtravel distance d to 250 N	0.898 in (22,8 mm)
Overtravel distance f to 400 N	1.031 in (26,2 mm)
Overtravel distance h-c to 600 N	1.130 in (28,7 mm)

Tested according DIN EN ISO 13856-2, Test Unit round 80mm, Actuating Point C3, Temp. 20°C

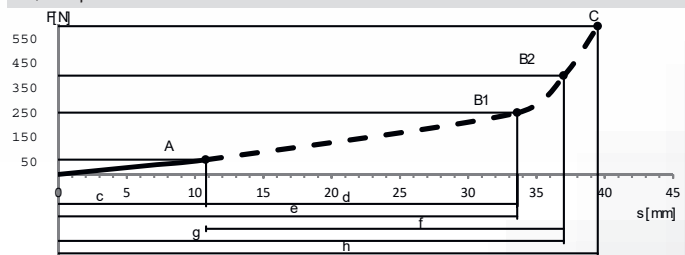

Test-Speed 200 mm/s (7.874 in/s)

Actuation Force F^A	60,6 N
Actuation distance c	0.445 in (11,3 mm)
Overtravel distance d to 250 N	0.878 in (22,3 mm)
Overtravel distance f to 400 N	1.024 in (26,0 mm)
Overtravel distance h-c to 600 N	1.126 in (28,6 mm)

Tested according DIN EN ISO 13856-2, Test Unit round 80mm, Actuating Point C3, Temp. 20°C

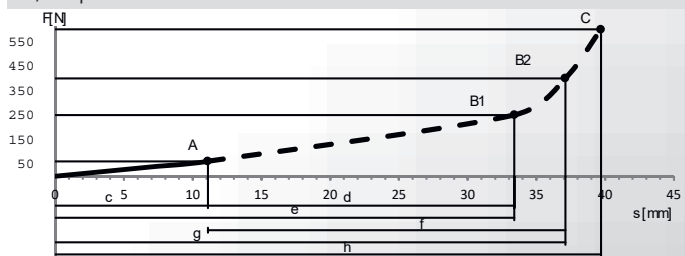

The response time of the used controller affects the measured overtravel distances of the contact edge.

Technical data

Material properties

General	
Tear strength	3
Ultimate tensile strength	3
Rebound elasticity at 20 °C	2
Resistance against permanent deformation	3
Abrasion	3
Elongation @ Tear	3
Cold flexibility	2
Heat stability	2
Oxidation stability	1
UV-stability	1
Weather resistance	1
Flame resistance	6
Ozone (50 ppm)	1

1 = very good → 6 = insufficient

Chemical resistance	
Water (dist.)	1
Dilutes acid	1
Dilutes base	1
Not oxidizing acids	2
Oxidizing acids	2
ASTM-oil No. 3	6
Mineral oil	2
Brake fluid	2-3
Antifreezing admixture	1
Gasoline	5
Diesel	2-3
Alcohol	1

1 = no effects	Permanent contact
2 = few effects	Some contact
3 = medium effects	Some contact
4 = noticeable effects	Reduced contact
5 = severe effects	Very brief contact
6 = extreme effects	Avoid contact



The listed properties are considered as guideline.
Critical application must be practically tested by the customer.

Assembly system

The KS 4 PRO Plug 'N' Sense System

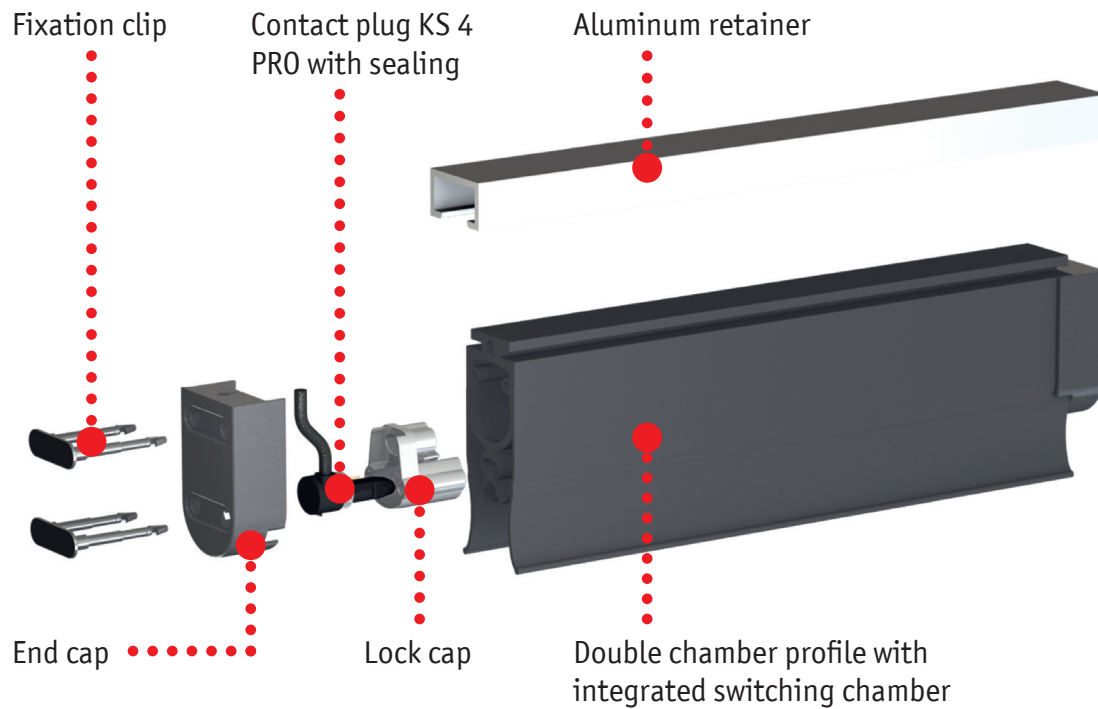

KS 4 PRO W or L XX,Xm - 25.30-Set

- 
1x KS 4 PRO plug with protective cap
(resistor 8.2 kOhm or XX,X m cable)
- 
1x Lock cap
- 
1x Fixation clip
- 
1x End cap 25.45

Assembly instructions

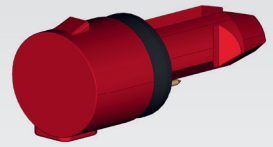

Safety contact edges may only be assembled and installed by authorized personnel!
ASO GmbH excludes all liability for damage caused of an incorrect assembly and installation of the contact edges!

Due to packaging it might happen that the lip of the profile is undulated. This appearance will not affect the functionality at all. This kind of appearance will in any case not be a reason for complaints!



Read all instructions first before installing / setting up the product!
Do not drink any alcohol or take any drugs before or during the setup of the product and follow the safety instructions carefully.

Note warnings and disclaimers!

To avoid the risk of crushing while assembling or mounting, Safety gloves must be worn!



1. Cutting the safety-contact-edge

The safety-contact-edge is cut 24 mm shorter than the final length dimension to allow for the length of the end caps on each end. Make sure that the cut surfaces are rectangular and clean, so the cut should be made starting at the chamber side of the safety edge. Special scissors or table lever blade offered by ASO should be used for this purpose.

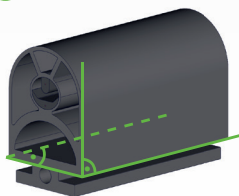
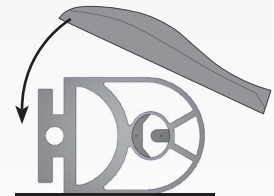
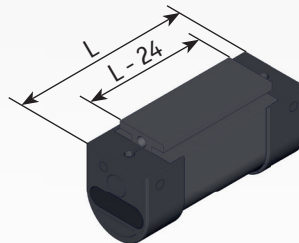

2. Preparing end caps

a) Water drain plugs

For installations in contact with water, it is necessary to remove water drain plugs. For vertical mounting, remove the two markings in the lower end cap, for horizontal mounting, remove the two markings in both end caps.

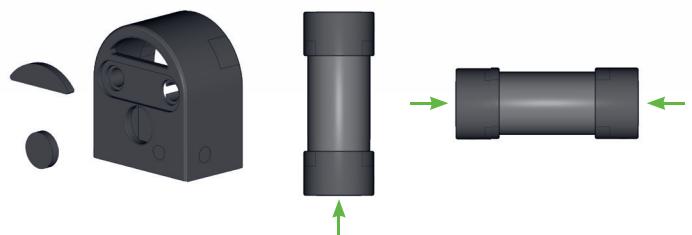

b) Notch for the sealing lip

When assembling safety-contact-edges with sealing lips, the end caps have to be notched where indicated to allow for the sealing lip(s).



c) Connection cable

Choose desired cable exit of end cap. If necessary, stitch through the marks.

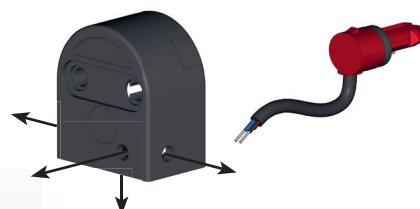

3. Insert lock cap

Push the lock cap straight into the hollow chambers around the internal switching chamber until it is tightly against the cut surface of the profile. Then check whether the outer wall of the switching chamber abuts the lock cap. Slight rotational movements of the lock cap can additionally cause this. For the required sealing, the switching chamber must not throw any waves.

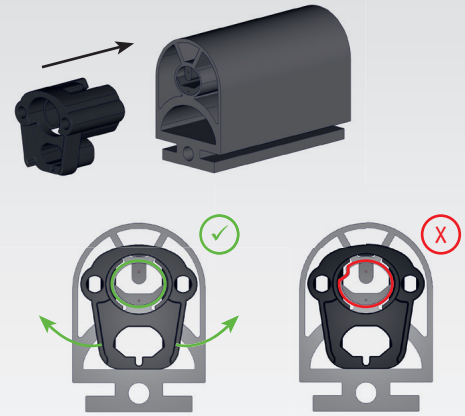
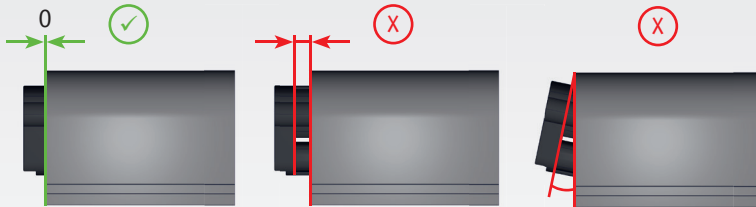

4. Insert the contact plug

Remove the plug from its protective cap, making sure not to touch the black sealing compound. Insert the plug by pushing it in straight aligned so that the self-adhesive sealant does not touch or stick to the lock cap. Make sure the attachment point of the plug is as close to the lock cap as possible. Then press in the plug a second time. Optionally, an assembly aid available from ASO can be used.

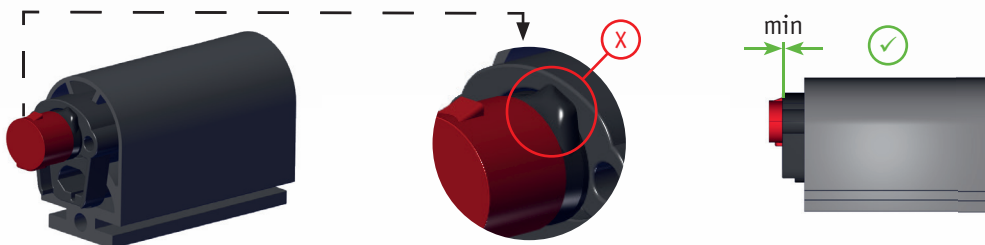
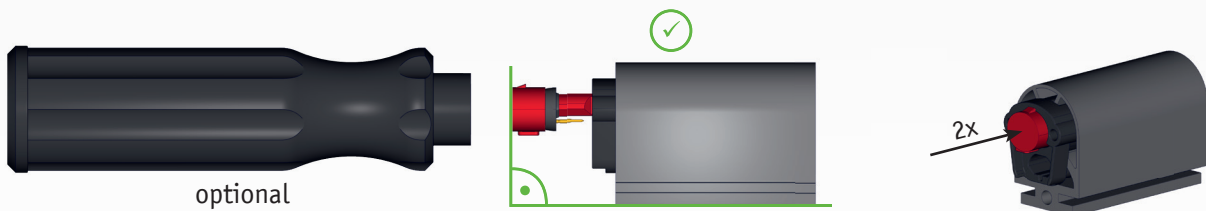

5. Put on end caps

Push the end cap onto the safety edge and fix it with the clip until it rests in the predetermined position of the end cap and noticeably locks in the lock cap. Then press the fixation clip a second time. For bigger safety edges, the end cap is fixed in the profile bottom by an additional fixing clip.

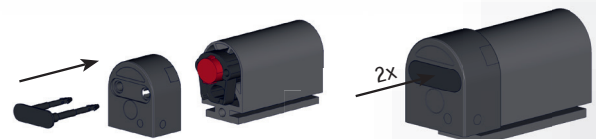

6. Electrical testing of the safety contact edge

Measure the contact strip with an ohmmeter. The resistance must be $8.2 \text{ k}\Omega \pm 500 \Omega$ when the end contact strip is not actuated, and it is indefinitely high when the through contact strip is not actuated. With actuated limit contact strip and through contact strip, the resistance must not exceed 500Ω .



Mounting instructions

Safety contact edges may only be assembled and installed by authorized personnel!

ASO GmbH excludes all liability for damage caused of an incorrect assembly and installation of the contact edges!



Read all instructions first before installing / setting up the product!

Do not drink any alcohol or take any drugs before or during the setup of the product and follow the safety instructions carefully.

Note warnings and disclaimers!

To avoid the risk of crushing while assembling or mounting, Safety gloves must be worn!



1. Cutting aluminum retainer

1.A The aluminum retainer has to be as long as the final dimension of the contact edge.

1.B For contact edges with lateral clip feet, the cutting dimension of the aluminum retainer must be 24 mm shorter than the final dimension of the finished contact edge.

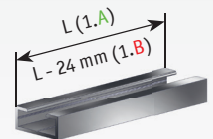

2. To facilitate installation of the safety contact edge, the aluminum retainer may only be attached to even surfaces. If the safety contact edge is mounted in a bend, the radius must not be more than specified.



3. The aluminum retainer must be fitted with countersunk screws or rivets. A diameter of 4 mm is sufficient. The holes of 4.5 mm must be evenly distributed over the entire length of the aluminum retainer with distances between them not exceeding 300 mm. They have to be countersunk according to the screw. Pan- or round-head screws should not be used. Otherwise the connecting wire in the aluminum retainer could be damaged.



4. In order to lead the connecting wire through the aluminum retainer, an 8 mm hole has to be drilled in the appropriate place. Carefully remove the burr from both sides.



5. In order to make the safety contact edge fit in easier, the aluminum retainer and the safety contact edge should be sprayed with soapy water. Once the soap suds have evaporated the contact edge is firmly fitted in the aluminum retainer. To prevent a subsequent slipping of the safety contact edge talcum powder, oils or similarly durable lubricants may not be used!

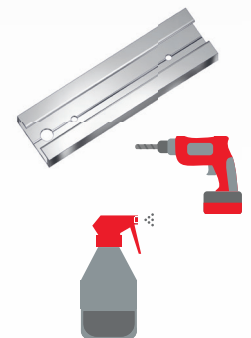

6. Safety contact edges with a c-base have to be clipped with one side into the aluminum retainer. Then press in the complete c-base. Pulling or pushing the safety contact edge into the aluminum retainer can cause damage to the contact edge and should be avoided at all costs.



7. Safety contact edges with collateral c-bases at first have to be pressed in at one side into the aluminum retainer. Then press in the other c-base. Pulling or pushing the safety contact edge into the aluminum retainer can cause damage to the contact edge and should be avoided at all costs.



8. Safety contact edges with a t-base have to be pushed into the aluminum retainer.

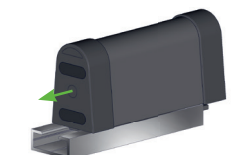

Any other methods of fastenings are only permitted on prior agreement with the manufacturer!
When mounted at sectional doors the use of stopper (depending on profile) is recommended.

Warnings and disclaimers

1. Preparations / set up

All SENTIR edges are inspected and tested before being shipped to ensure against damage. If the shipping container appears to be damaged, please notify the supplier immediately.

WARNING: Do not bend or fold as damage may occur.

2. Handling / Storage



To avoid the risk of crushing, Safety gloves must be worn!

Recommended:

- Ideal storage and temperature -25C to 75C (or if different per edge)
- Ideal storage: Dry, clean and flat
- Transport SENTIR edges in the supplied packaging to where they are to be installed.

Not Recommended:

- Significant bending of SENTIR edges
- Storing SENTIR edges vertically
- Extreme temperature fluctuations
- Outdoor storage
- Pulling SENTIR edges by the cable
- Stack up SENTIR edges without packaging

3. Maintenance



To avoid the risk of crushing, Safety gloves must be worn!

Installation and electrical work must be performed by authorized electricians.

- If damage occurs, such as brittle or torn rubber profile, non-tight switching chamber, insufficient contact resistance in the activated state or similar, the SENTIR edge must be replaced immediately.
- During the maintenance operations, disconnect the machine's prime mover before working in the SENTIR edge system. Observe all applicable electrical safety precautions.
- Cleaning: The profiles should be kept clean of deposits such as swarf (fine metallic fillings or shavings removed by cutting, grinding or any other mechanical process), debris, and other foreign materials to prevent damage or dead-zones. It is permissible to use warm water and a mild detergent to clean the surface of the area.
- Important: Do not use solvents
- Stop the machine, clean the profiles and allow them to dry off. Inspect the surface of the profile for the damage. Any damage that punctures the profile could let material or liquid in. It must be dealt with immediately. Check that all endcaps, corners and joints are secure and free from damage. Damaged parts must be replaced immediately.
- Test the profile operation. If these checks reveal any problem, do not allow use of the machine until the problems are rectified.

Warnings and disclaimers

Thorough examination and test:



To avoid the risk of crushing, Safety gloves must be worn!
Installation and electrical work must be performed by authorized electricians.

Recommended twice yearly or after damage. To be done by a person trained or qualified in electrical and mechanical engineering.

- Isolate the power source to the machine. Observe electrical safety precautions.
- Disconnect the SENTIR edge from the control unit
- Inspect the SENTIR edge and components thoroughly for mechanical damage.
- Test the SENTIR edge operations.
- If the inspections tests performed reveal any problems, do not allow use of the machine until they are rectified. Record the inspection and test in a written log.

The sequence of examination operations varies at different applications. The trained staff is responsible for the correct sequence of examination operating in terms of safety.

TAMPERING WITH COMPONENT PARTS WILL INVALIDATE WARRANTY.

In the event of problems contact the supplier.

4. Precautions (General)



To avoid the risk of crushing, Safety gloves must be worn!
Installation and electrical work must be performed by authorized electricians.

- Always adhere to the local and national electrical code specifications when wiring SENTIR edge and other controls. Wire the SENTIR edge into controls as specified by the control manufacturer.
- The safety regulations issued by the Trade Association and those for electrical installation must be considered. Failure to comply with the safety regulations may result in severe or fatal injury or serious damage to property.
- Be sure to disconnect all power to the operator before installing the SENTIR edge.
- The gate or door must be in the fully opened or closed position before installing the SENTIR edge.
- Install correctly and test the SENTIR edge for proper operation.
- Do not operate equipment without a properly working and correctly wired SENTIR edge attached.

5. Disclaimer:

In no event will the manufacturer be responsible or liable for indirect or consequential damages resulting from the use or application of this equipment.

If applied incorrectly, serious injury or death can occur.

The user must observe the safety instructions in this operating instructions manual, the country-specific installation standards as well as all prevailing safety regulations and accidents prevention rules.

The information contained in this operating instructions manual is provided without liability and is subject to technical modifications.

There are no residual risks, provided that the safety instructions as well as the instructions regarding mounting, commissioning, operation and maintenance are observed.

Exclusion of Liability: The manufacturer shall accept no liability for damages and malfunctions resulting from defective mounting or failure to comply with this operating instructions manual. The manufacturer shall accept no liability for damages resulting from the use of unauthorized spare parts or accessories.

Beyond that, the current version of ASO's General Terms and Conditions shall apply.

Declaration of conformity

EG - Konformitätserklärung (gemäß Anhang II 2006/42/EG)
EC Declaration of conformity (according annex II 2006/42/EC)
Déclaration de conformité CE (selon annexe II 2006/42/CE)



Hiermit erklären wir, dass die nachfolgend bezeichneten Schaltleisten

We hereby declare that the following products of sensing contact edges

Par la présente nous déclarons que les produits suivants de la série barres palpeuses:

SENTIR edge 25.45

SENTIR edge 25.45

SENTIR edge 25.45

zur Kombination mit den Sicherheitsschaltgeräten der Baureihe

for the combination with safety relays of the model range

en combinaison avec les relais de sécurité

ELMON relay 31
ELMON relay 32
ELMON relay 34
ELMON relay 35
ELMON relay 39*
ELMON relay 41*

ELMON relay 31
ELMON relay 32
ELMON relay 34
ELMON relay 35
ELMON relay 39*
ELMON relay 41*

ELMON relay 31
ELMON relay 32
ELMON relay 34
ELMON relay 35
ELMON relay 39*
ELMON relay 41*

aufgrund ihrer Konzipierung und Bauart sowie in der von uns in Verkehr gebrachten Ausführung, den einschlägigen grundlegenden Sicherheits- und Gesundheitsanforderungen der nachfolgenden EG-Richtlinien und Normen entspricht:

satisfies the relevant essential health and safety requirements of the EC directives and standards listed below on account of its design and construction, as does the version brought to market by us:

de par sa conception et sa construction, ainsi que dans les modèles mis en circulation par nos soins, répondent aux exigences de base pour la sécurité et la santé des directives et normes CE suivantes :

EN ISO 13856-2
EN 12978
EN ISO 13849-1
2011/65/EU; 2015/863/EU RoHS
(EG) Nr. 1907/2006 - REACH

EN ISO 13856-2
EN 12978
EN ISO 13849-1
2011/65/EU; 2015/863/EU RoHS
(EC) Nr. 1907/2006 - REACH

EN ISO 13856-2
EN 12978
EN ISO 13849-1
2011/65/EU; 2015/863/EU RoHS
(EC) Nr. 1907/2006 - REACH

*EG-Baumusterprüfung
 Notified Body 0044
 TÜV Nord Cert GmbH
 Langemarckstraße 20
 D-45141 Essen
 Nr. 44 205 13031818

*EC type-examination
 Notified Body 0044
 TÜV Nord Cert GmbH
 Langemarckstraße 20
 D-45141 Essen
 No. 44 205 13031818

*Examen CE de type
 Notified Body 0044
 TÜV Nord Cert GmbH
 Langemarckstraße 20
 D-45141 Essen
 N° 44 205 13031818

Diese Konformitätserklärung entbindet den Konstrukteur/ Hersteller der Maschine nicht von seiner Pflicht, die Konformität der gesamten Maschine, an der dieses Produkt angebracht wird, entsprechend der EG-Maschinenrichtlinie sicherzustellen.

This declaration of conformity does not relieve the designer / manufacturer of the machine from his obligation to ensure that the conformity of the entire machine to which this product is attached satisfies the corresponding EC directive.

Cette déclaration de conformité ne délie pas le constructeur / fabricant de la machine de son obligation d'assurer la conformité de l'ensemble de la machine à laquelle ce produit est apposé selon la directive CE.

Hersteller und Dokumentationsbevollmächtigter

Manufacturer and attorney of documents

Fabricant et agent de documentation

ASO GmbH
 Hansastr. 52
 D-59557 Lippstadt
 Lippstadt, 15.06.2021



D. Verhufen
 - Geschäftsführer - CFO - Gérant -



Headquarters Europe

ASO GmbH
Hansastraße 52
59557 Lippstadt

Tel +49 2941 9793-0
Fax +49 2941 9793-299
www.asosafety.de
sales-eu@asosafety.com

Headquarters USA

ASO Safety Solutions Inc.
350 N Frontage Road
Landing, NJ 07850

Phone +1 973 5869600
Fax +1 973 5861590
www.asosafety.com
sales-us@asosafety.com

Headquarters Asia Pacific

ASO Safety Solutions Nanjing Co. Ltd.
Jinma Lu 3 Maqun Scientific Park
210049 Nanjing

Phone +86 25 856 73990
www.asosafety.cn
sales-cn@asosafety.com



DOC0000673 Technical data Rev 06
as of 14.03.2023
Technical changes reserved